

KEKB Power Supply Interface Controller Module

A. Akiyama, T. Nakamura, M. Yoshida, T. Kubo, N. Yamamoto and T. Katoh

KEK, High Energy Accelerator Research Organization
1-1 Oho, Tsukuba 305, Japan

Abstract

There are more than 2,500 magnet power supplies for KEKB storage rings. It was a very important problem to solve the problem how to control such a large number of power supplies distributed around the ring. Almost all the magnets are powered by independent power supplies. The cost of interfaces is also a large problem. After discussions, we decided to develop an interface controller module that will be mounted in the power supply controller or power supply itself. It has a 16-bit microprocessor, ARCnet interface, trigger pulse input interface, and general-purpose parallel interface to the power supply. The microprocessor receives commands from the control system via ARCnet, analyzes them and sends signals to the power supply. It does not have DAC or ADC for simplicity. DAC is located in the power supply controller or power supply itself. And the output current is monitored by analog scanning sub-system. We have also developed an ARCnet driver module on VME-bus with four channels of ARCnet interface. On each ARCnet segment, up to twenty power supply interface modules are connected. Modules are now being tested in the QCS magnet power supply system.

1 Introduction

KEKB accelerator is composed of two storage rings, e.g. an 8GeV electron storage ring and a 3.5GeV positron storage rings. Both are now being constructed in the same tunnel of TRISTAN, a 33GeV electron-positron colliding accelerator which was shut down and removed from the tunnel. KEKB storage rings are designed for producing B mesons in the asymmetric way. The parameters of the storage rings should be adjusted by the operators or machine physicists through the control system[1]. For these purposes, almost all magnets are powered by independent power supplies. Therefore, there are more than 2,500 magnet power supplies in various categories. There are small number of very high current power supplies, several hundreds of medium current ones, and more than 1,600 steering magnet ones. There are unipolar power supplies and bipolar power supplies.

To connect those power supplies with the control computer system is another problem. If you connect the power supply by using parallel interface, more than 30 signal lines are needed to get status signals, to control and to set DAC value signals. It gives the total of 100,000 signal lines around the storage rings. In order to reduce

the number of lines and the cost of wire handling at the same time, we decided to connect the power supplies by serial field buses. There were candidates of field buses such as ARCnet, CANbus, Profibus, and so on. In Japan, not only KEK but also companies had not enough experiences on CANbus, Profibus, and new ones. But ARCnet had been used widely and we chose ARCnet as the field bus.

It is very convenient for us if there were power supplies that can be connected to ARCnet with the software protocol which we define. To satisfy this condition, at first, we asked the power supply manufacturers if they could implement such control interface inside their power supplies but the answers were negative. Then, we decided to develop a power supply interface controller module in Euro-Card format which can be plugged into the power supply and link it to the control system.

2 Requirements for the module

As described above there are several types of power supplies. There are unipolar and bipolar power supplies, new and modified old ones, 12 bits and 16 bits in accuracy, required specifications for such power supplies are widely distributed. We decided to design the software installed on the Power Supply Interface Controller Module(PSICM) recognizes which kind of power supply is connected. In other words, each power supply must have its unique type and serial number data in itself. The PSICM can be used for other purposes by changing software written in EPROM.

The magnet power supplies will be operated in three modes; direct, constant slewing rate, and wave-generator modes. In all modes, the DAC set value is sent to the power supply by either software commands or hardware start pulse signal.

2.1 The direct output mode

This is the most fundamental mode for diagnostics, in which the magnet current is set directly to a certain value.

2.2 The constant slewing rate mode

Usually the magnet current is set by using this mode. The parameters are target current value, time to be used and delay time before starting. In this mode, when the command is accepted, the microcontroller calculates the change during the unit time period(e.g. 1ms) and magnet current will be incremented every unit time after the given

delay time. The sequence can be triggered either by software start command or hardware start signal.

2.3 The wave-generator mode

Sometimes it is required to change magnet currents of different types synchronously and proportionally or in the calculated manners. In this case series of magnet currents for each magnet are calculated by the application program and put into an array which will be sent to PSICM via ARCnet. After PSICM receives all the data, a software start command or hardware start signal will be sent to the module and the module passes the output value to the power supply every pre-determined interval till the data runs out.

In the extreme case it is requested to the control system to be able to adjust magnet currents of 800 steering magnets in 400ms synchronized with each other for keeping the beam stable in the storage ring. The fundamental hardware specifications are listed in Table 1.

Table 1. Table of the basic parameters of PSICM.

Physical size:	100mm x 160mm x 6 HP
Network connectors:	2 x RJ45 STP connectors
Signal connector:	DIN 64-pin connector
Microcontroller:	AM186 16-bit Microcontroller
Clock frequency	20MHz
Data memory:	256kB SRAM(128kB x 2)
Program memory:	256kB EPROM (128kB x 2)
Power required:	5V 0.4A
Communication interface	
Network:	2.5Mbps ARCnet Backplane mode
Nr. of nodes:	20
Cable:	Category 5, STP cable
Max. length:	~ 150m
Power supply interface	
Dedicated lines	
CBON (out)	1 bit (Momentary)
CBOFF (out)	1 bit (Momentary)
PWRON (out)	1 bit (Momentary)
PWROFF (out)	1 bit (Momentary)
POL+ (out)	1 bit (Momentary)
POL- (out)	1 bit (Momentary)
DAC strobe (out)	1 bit (Momentary)
RESET (out)	1 bit (Momentary)
Attention (in)	1 bit (Momentary)
General purpose I/O lines	
Register address (out)	4 bits
Read strobe (out)	1 bit (Momentary)
Write strobe (out)	1 bit (Momentary)
Data input (in)	16 bits
Data output (out)	16 bits

3 Hardware configuration

The PSICM itself was designed as a general-purpose module. Physically, it has the shape of 100mm x 160mm Euro-Card format with a DIN 64-pin connector as shown in Fig. 1. Intelligence is provided by a 20MHz 16-bit microcontroller chip of 80186 type. Communication with the host VME computer is done through the ARCnet interface controller chip and a driver module. Interface to the power supply is done through a 64-pin DIN 41612 type-C connector and DC power consumed by the module is also supplied through this connector.

The ARCnet cable is connected through two RJ-45 STP(Shielded Twisted-Pair) connectors. One is for the upstream and the other is for the downstream. The circuit diagram is shown in Fig. 2.

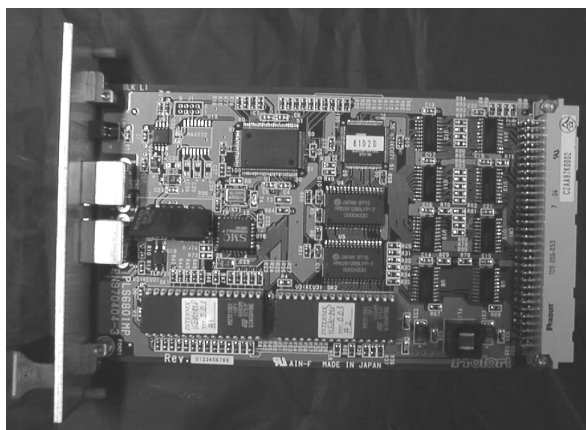

Figure 1. A Power Supply Interface Controller Module

3.1 Microcontroller

A 16-bit microcontroller 80186 type is used in the PSICM to control a power supply and to handle ARCnet communication with the VME control computer in the KEKB control system. Two 128k bytes static RAMs are used for data memory storage. The programs are stored in a pair of EPROMs. Each EPROM has a capacity of 128k bytes. The clock frequency of the microcontroller is 10MHz. The chip provides a watch-dog timer facility for recovery of the system from the dead-lock problem.

3.2 ARCnet Interface

The module is connected to the host VME computer via single shielded twisted-pair cable with two conductor pairs, one for the ARCnet and the other for the start signal for synchronous ramping. The back-plane mode is adopted in KEKB control system and up to twenty PSICM can be connected in one segment. The ARCnet is a token-bus network and PSICMs are logically connected to a bus line but shielded twisted-pair cables are used to connect PSICMs in a daisy-chain manner.

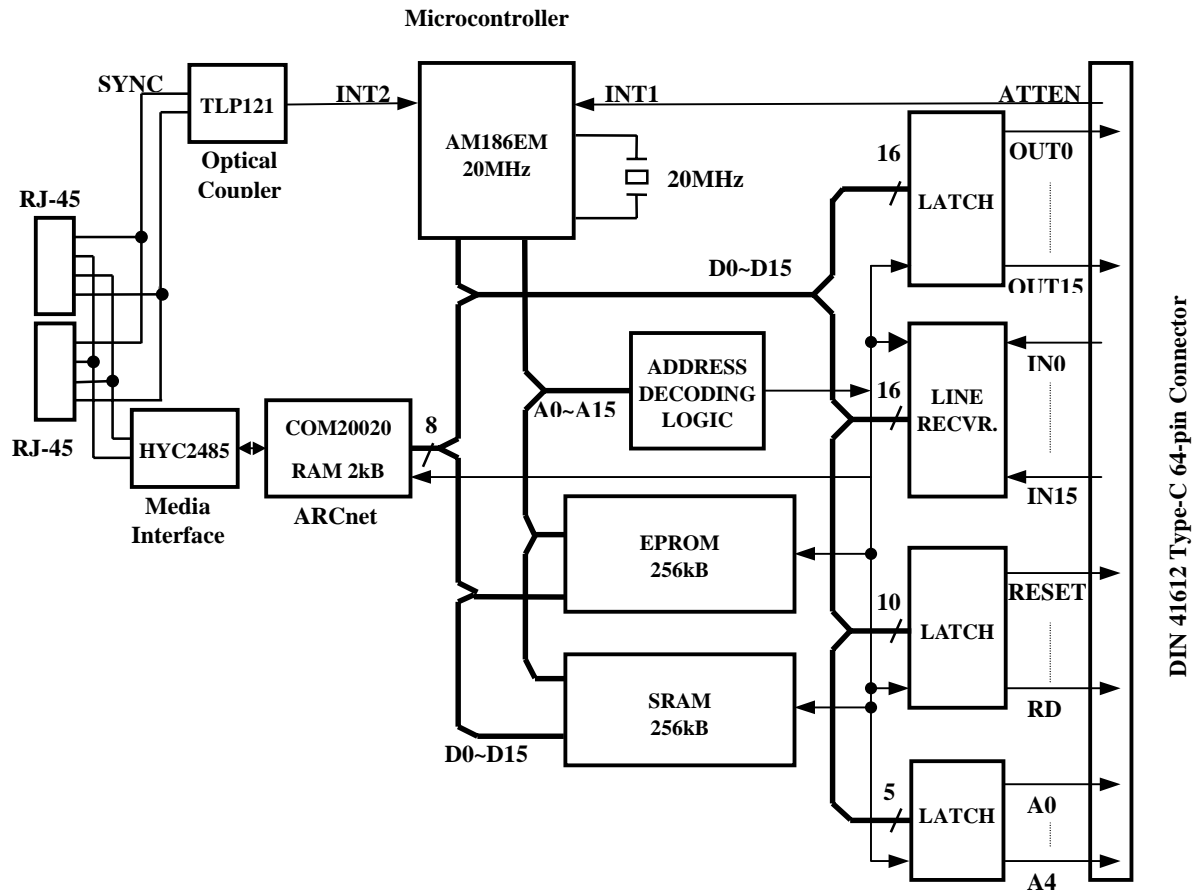

Fig. 2. Circuit Diagram of Power Supply Interface Controller Module

4 Software

The magnet power supply has its unique data such as power supply type identification code, the serial number, and the calibration constants in the NVRAM in the power supply itself. These data are read by the PSICM at its initial start-up phase.

The main routine of the program waits for the ARCnet interrupts, attention signal from the power supply, start signal input or timer interrupts. The ARCnet interrupt shows the arrival of commands from the VME computer and the command is analyzed and executed. The commands includes the three major operationing modes of the power supply, e.g. direct mode, constant slewing rate mode, and the wave-generator mode.

Attention signal from the power supply shows changes in status of the power supply and the program checks the status and send them up to VME computer if it must be reported. The start signal interrupt triggers the output to DAC and the program continues to output periodically by the tick of the internal timer. The timer interrupts are used to get constant period of 1ms and 10ms.

If the power supply has a circuit breaker in the power input circuit, it can be switched on/of by sending CBON/CBOFF commands. The output current is switched on/off by sending PWRON/PWROFF commands. The polarity of the output current can be changed by sending POL+/POL- commands. Alarm status can be reset by the RESET command when the power supply error occurs.

The PSICM routinely watches the status of the power supply and sends the alarm message to the host VME computer if the status change is detected and it must be noticed. The output current of the power supply will be monitored by the VME computer using a scanning analog volt-meter.

5 QCS Magnet power supplies

KEKB storage rings are under construction and at present, we have only a part of magnet power supplies. We have installed PSICMs in the QCS(Quadruple magnets for the Colliding points using Super-conducting) and correction

magnet power supplies as shown in Fig. 3. In the figure, you can see PSICMs are installed in the magnet power supplies. QCS magnets are being tested now with PSICM in themselves. The steering magnet power supplies are now manufactured by a company.



Fig. 3. PSICMs installed in QCS correction magnet power supplies.

6 Conclusion

The PSICM was developed for the KEKB magnet power supplies and it reduces number of cables and number of connections dramatically. The PSICM itself is designed general purpose module in standard format so that it can be used for various purposes by the modification of the software on the module.

7 Acknowledgments

We wish to express our thanks to the members of KEKB controls group and KEKB magnet group for their cooperations. We also thank Prof. Shin'ichi Kurokawa for encouraging the development of PSICM.

8 Reference

- [1] "Present Status of the KEKB Control System", T. Katoh, et al., ICALEPCS'97, this conference.